



Soft Shade System Installation Instructions

Introductions

The **Soft Shade Clutch System** is used to manually raise & lower a soft shade evenly. The maximum shade length is 12ft with 0.9 mm lift cords. The maximum total weight of the shade not including the headrail or dustboard is **15 lb for a Slim Clutch and brackets (1 1/2" width)**; and **30 lb for a Standard Clutch and brackets (2 1/8" width)**. By pulling the beaded chain loop, an operator can raise or lower a soft shade easily, smoothly and precisely. Fig.1 shows the back view of an assembled soft shade. See the note at the end of these instructions titled **"Using Grommets To Make A Shade That Has Almost No Light Gap At The Side Edges"** for an extra tip on making a better shade. The shade must have a weight bar at the bottom of the shade for smooth operation. We suggest using our weight bar, stk# BR6/4 or BR6/8. The shade can be made with Encased Lift Cord on the edges of the shade as shown in Fig.2a, or without rings on the outside edges of the shade, Fig.2b. We recommend using Encased Lift Cord on the edges of the shade. **It is important** to consider the bracket position and Encased Lift Cord spacing **before** you attach Encased Lift Cord to your shade. Brackets should be from 7" to 12" from the edges of the shade and 8" from each other. The space should not be larger than 8" because each lift cord can lift no more than 5 lbs. and the fabric may sag between rows of Encased Lift Cord. The topmost tack Encased Lift Cord on the shade should be at least 5" below the dustboard. For narrow shade (24" wide or less) lift cord and bracket arrangement, please refer to the last section on page 4.

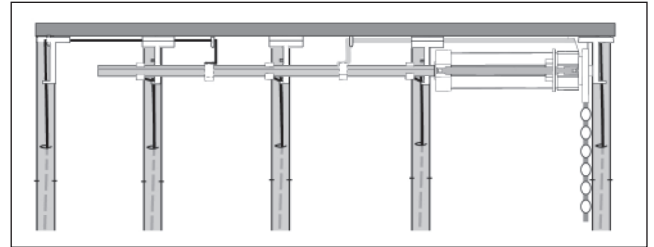

Fig.1 Back View of an Assembled Soft Shade

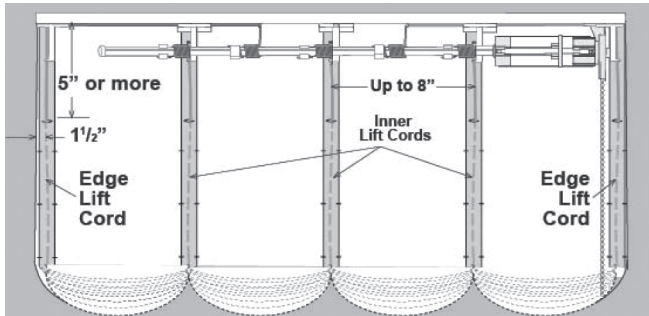

Fig.2a. with Encased Lift cord on the outside edges

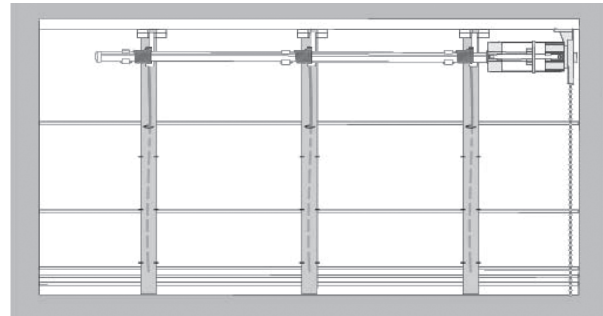

Fig.2b. without Encased Lift Cord on the outside edges

Fig.2 Shade Lift Cord Arrangement

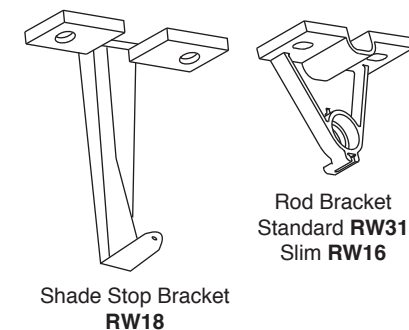
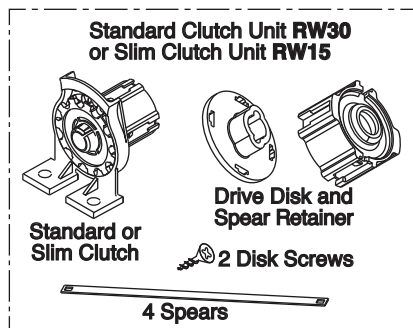
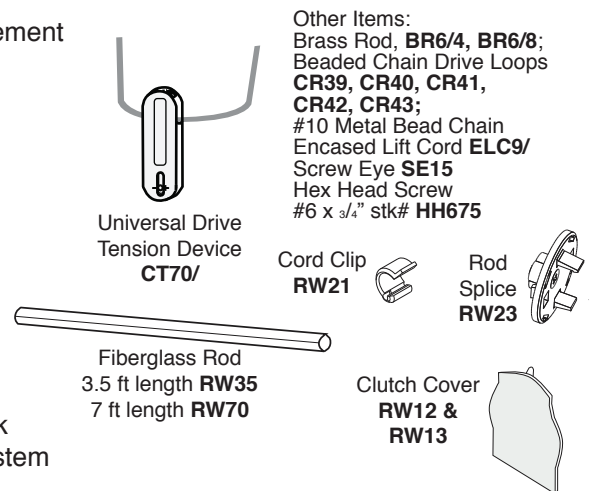

Fig.3 Basic Components and Stock Numbers For Soft Shade System



Fabrication We strongly suggest reading the entire instructions before actually starting fabrication

Step 1. Make and cut the dustboard to the shade width. You may either paint the dustboard, wrap it with fabric, or leave it bare. Staples or Velcro® may be used to secure fabric to wood. Lay dustboard on the worktable with bottom facing up.

Step 2 . If edge lift cords are used, center screw eyes (Stk#SE15) at each end of the dustboard 1 1/2" from the edges shown in Fig.4, and the screw eyes should be in line with the edge rings on the shade. Cut the fiberglass rod 7" shorter than the length of the dustboard by gradually rotating the rod a complete turn as you cut with a fine tooth hacksaw blade to obtain a clean cut edge. File off rough edges if necessary.

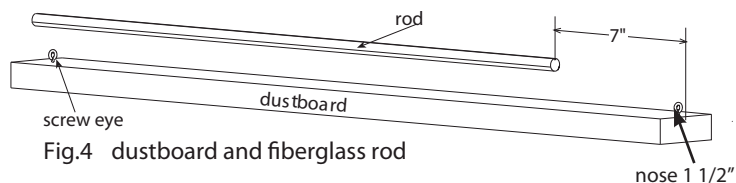

Fig.4 dustboard and fiberglass rod

Step 3 . Press the drive disk completely onto the rod and use two disk screws to secure them. Slide spear retainer onto the other end of the rod. Make sure the spear retainer is oriented with hollow end toward the drive disk as in Fig.5.

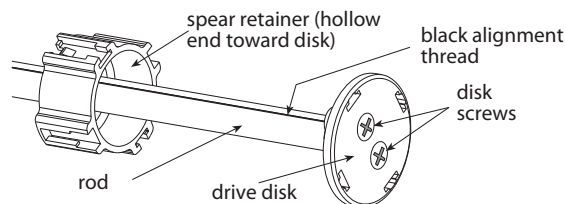

Fig.5 rod, drive disk and spear retainer

Step 4. Use plastic bead chain for shades from 11lb to 15lb and metal bead chain for shades 15lb to 30lb. Insert bead chain loop (stk#CR39 to CR43) into the clutch by slipping a loop thru the opening of the clutch as shown in Fig.6a. While holding the clutch foot with one hand, use the other hand to rotate the beads on the bead chain loop into the teeth of the sprocket, Fig.6b, until the bead chain loop is completely inserted into clutch, Fig.6c. If metal bead chain (stk#BCH10 or BCK10) and chain connectors (stk#BCC10) are used, cut the metal bead chain 2.5 times the shade length for the 15lb. Clutch and 3.5 times for the 30 lb clutch, or longer to operate the shade properly. We strongly recommend using bead chain splicing tool (stk#WST19) to make endless chain loops to avoid extra bead chain hanging down on the floor or where small children can reach it. Clip the clutch cover onto the outside end of the clutch.

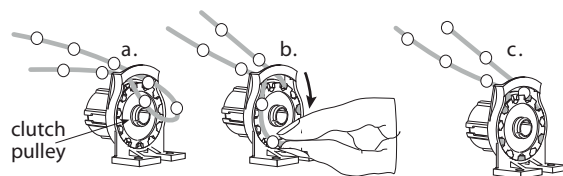

Fig.6 Insert Bead Chain Loop into clutch

Step 5. Slide either end of a spear into the groove on the clutch making sure the hole on the spear securely snaps and locks onto the locking barb in the clutch as shown in Fig.7. Once the spear is inserted, it can not be removed. Insert the other three spears in the other three grooves on the clutch.

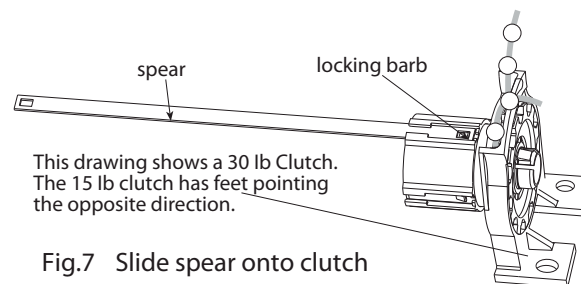

Fig.7 Slide spear onto clutch

Step 6. Slide spears thru the drive disk (see Fig.8). Insert the spears in the grooves on the spear retainer all the way until they are locked in.

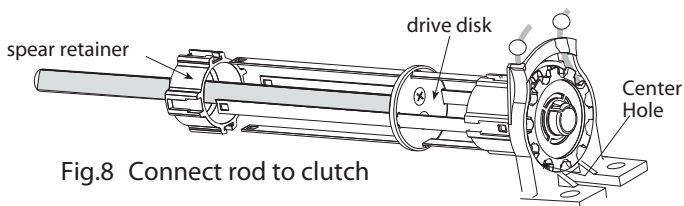

Fig.8 Connect rod to clutch

Step 7. All inner lift cords will use a bracket and outer cords use screw eyes. Slide one bracket for each inner lift cord with bracket feet (see Fig.9) pointing toward the clutch. In Fig.9, for example , the shade uses 3 interior lift cords and 2 edge lift cords. #2, 3 & 4 lift cords are inner lift cords. #1 (screw eye #1) and #5 (screw eye #2) lift cords are edge cords. Screw eyes #3 and #4 are then used to route edge cords (#1 & #5) to the rod unless there are only two lift cords on the shade. Since most shades have more than 2 lift cords, this is usually not an issue. When only 2 lift cords are used on a shade, two brackets are used to route the edge lift cords to the rod (See section titled For Narrow Shades on page 4, and Fig.10). Remember 5 lbs maximum load per lift cords.

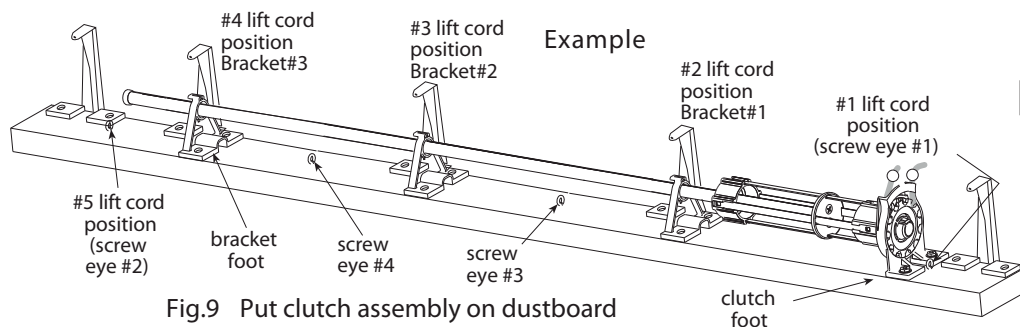

Fig.9 Put clutch assembly on dustboard

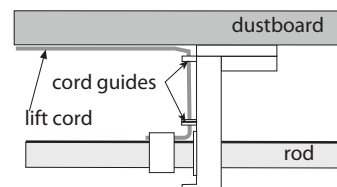

Fig.10 Attach edge lift cords for narrow shades

Rod Splicing Note: Although a one piece rod is best whenever possible, the rod can be spliced with 2 splice connectors **stk#RW23** as in Fig.11. Brackets can not be slid along the rod past the splice, so brackets should be positioned before splicing rods together. Align the black lines on both rods so when the parts are snapped together the black line will be straight. Both connectors must be attached firmly to their respective lengths of rod and disk screws must be flush without the heads protruding from the connector (see Fig.10a). Line up the connectors with the screws back to back, Fig.10b. Push the prongs of each connector into the holes of the other connector until the two parts snap together, Fig.10c.

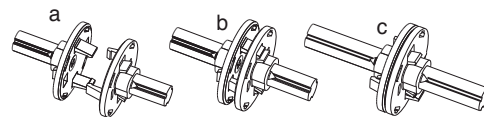

Fig.11 rod splice “snap” together

Step 8. Every row of Encased Lift Cord **MUST** have a shade stop to rout through. Place the shade stops in line with the Encased Lift Cord, overlapping legs with the legs of the brackets, if needed. See Figure 17 for placement sample.

Step 9. Position clutch/rod/brackets assembly on dustboard $\frac{1}{4}$ ” from screw eye #1 or if no edge lift cords are used, position 2” from edge of dustboard. Use a straight edge rule to make sure the clutch and the brackets are lined up properly, and the rod is centered on the dustboard. Temporarily screw clutch to the dustboard until ready to attach the screw eyes. Starting with lift cord position #2, slide the bracket along the rod to align the lift cord guides with the 2nd column of lift cord rings on the shade (see Fig.9 and Fig.10). Mark the bracket screw hole locations. Screw eyes will be positioned midway between brackets 1 & 2 and 2 & 3. Mark all remaining brackets and screw eyes in order of lift cord position. Remove clutch/rod/brackets assembly and attach screw eyes to dustboard. Screw clutch to dustboard with $\frac{3}{4}$ ” x #6 screws. Screw the brackets and shade stops to dustboard. Loosen screws on all brackets $\frac{1}{4}$ turn but not the clutch. Test to ensure rod moves freely on spears and through brackets. This system will not work properly if the rod does not move freely. If it does not, the problem will be related to improper alignment between brackets or clutch.

Step 10. The system will only use 0.9 mm lift cords.

Step 11. Before attaching lift cords (see Fig. 12), slide rod toward clutch until drive disk is all the way against clutch. Maintain drive disk contact with clutch whenever attaching lift cords. Turn the black alignment line on the rod so it points toward dustboard.

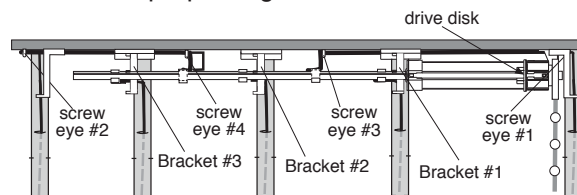

Fig.12 Cut and Attach lift cords

A. Edge lift cords.

Feed one lift cord up from Encased Lift Cord below screw eye #1, through shade stop and through screw eye #1, clutch foot center hole, center hole on bracket foot #1, screw eye #3 and make a knot at the end of the lift cord. Insert the cord into cord slot of a cord clip and knot into knot slot as shown in Fig.13a. **Align edge of cord clip with black alignment line on rod** as shown in Fig.13b with knot side facing away from clutch. Align the other side of the clip slightly past screw eye #3 as shown Fig.12. Push the clip onto the rod as shown in Fig.13b and 13c. For the other edge lift cord, feed up through the row of rings below screw eye #2, through shade stop and screw eye #2, center hole on the base of bracket #3, and screw eye #4. Knot and insert the lift cord into cord clip and put the cord clip onto the rod the same way as described for other edge lift cord.

B. Inner lift cords.

Thread inner lift cords up from the Encased Lift Cord through shade stop and through bracket lift cord guide and make a knot on the end. Insert cord into the cord slot on cord clip as shown in Fig.13a. Place the cord clip onto the rod with the knot side away from the clutch and the edge of the cord clip at the bottom of the rod (**opposite of the black thread**) as shown in Fig.14. All inner lift cord clips should be placed on the rod the same distance from their corresponding brackets. Make sure no lift cords are wrapped around the rod.

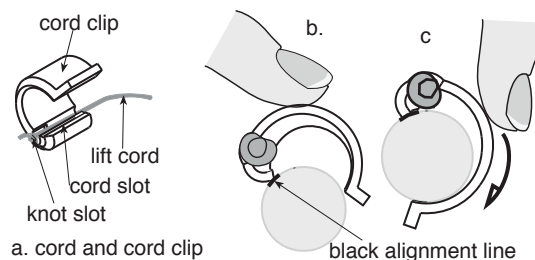

Fig.13 Put cord and cord clip onto rod

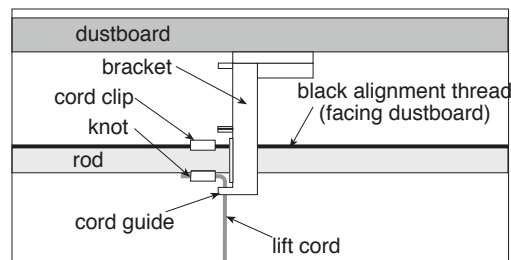

Fig.14 Attach inner lift cords

Step 12. Lightly tug each lift cord at the bottom of the shade to remove slack in the cord. Tie to the corresponding bottom ring. If necessary adjust the cord tension by re-tying the cord to the bottom ring. Run the shade up and down several times, and check for either too much tension or slack on the lift cords to make sure the cords are correct. Finally cut off the excess lift cord.

Step 13. Final installation in the window can be either inside or outside mount with angle irons.

Troubleshooting:

First check lift cords for too much slack or a tangled cord or cut too short. A misalignment of the brackets or clutch can also be the cause of many problems. This is easy to test by lowering the shade down completely and sliding the rod back and forth to ensure it slides completely free. If the shade works fine prior to installation but not after, the installation may have slightly twisted the dustboard due to an uneven wall or window. First try loosening the bracket screws no more than 1/4 turn from tight. If rod is still not free, try loosening the installation screws no more than 1/4 turn or adding shims.

Shade Stop Bracket For Every Row Of Encased Lift Cord Cord

Shade stop brackets, Skt#RW18, are designed to provide an even stopping point when raising a shade and prevent damage to the shade fabric because of over pulling. The shade stop bracket should be mounted on the side of the board where the shade will be attached. The shade stop bracket is mounted with two screws, one of the mounting screws is shared with the shaft bracket as shown in Fig. 17.

Note: The top row of grommets or sewing rings should be at least 5" from the mounting board (See Fig. 2a).

For Narrow Shades (From 15" to 24" Wide) - Lift Cord and Bracket Arrangement

You have to use short spears, Skt#RW10, for narrow shades (shade width 24" or less; and shade length can not exceed 108"). You should cut the fiberglass rod 6" shorter than the dust board length, instead of 7" as stated in step 2.

A. Shade Width From 15" to 20"

Use 2 lift cords and 2 brackets as shown in Fig.18a.

B. Shade Width from 20" to 24"

Use 3 lift cords and 3 brackets as shown in Fig.18b.

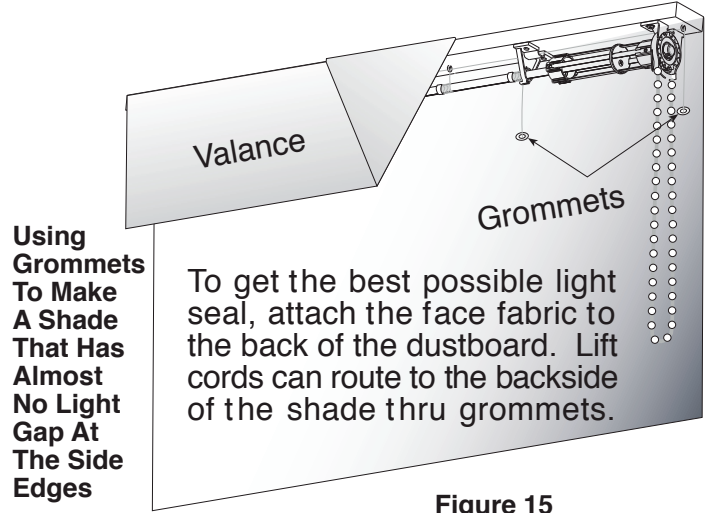

Figure 15

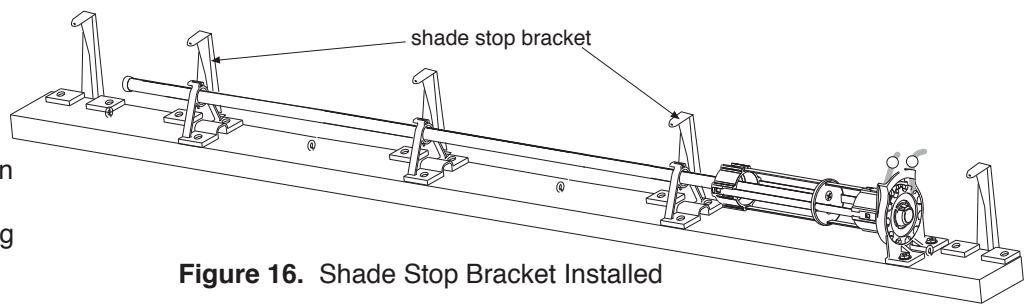
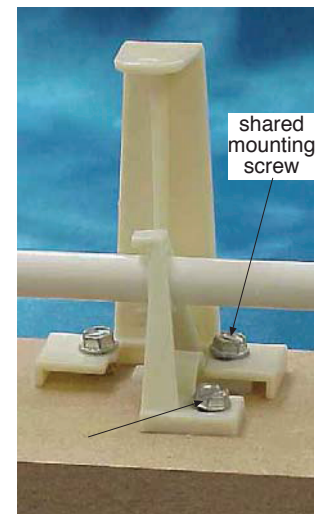

Figure 16. Shade Stop Bracket Installed



b. Shade Stop Bracket and Shaft Bracket

Figure 17. Shade Stop Bracket and Shaft Bracket

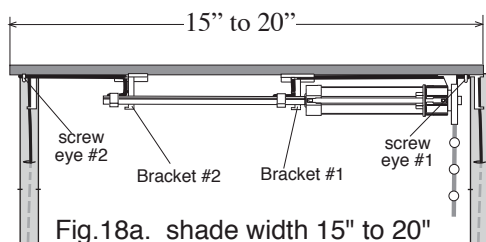

Fig.18a. shade width 15" to 20"

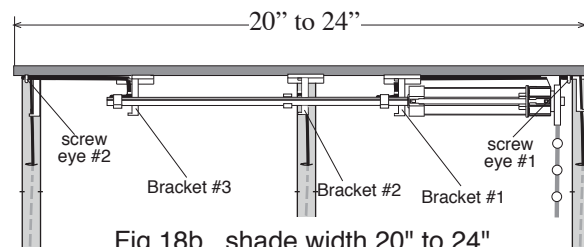

Fig.18b. shade width 20" to 24"

Figure 18. Narrow Shade Lift Cord and Bracket Arrangement