

Instructions For Fabric Shade Template (DYC51)

The Fabric Shade Template will help the user to mark ring positions on a fabric shade faster and less chance for making mistakes.

An example of figuring out the ring positions is given here as a reference. However, most users have their own way of figuring out the ring positions. You may follow the calculation below for your reference, or skip the calculation part.

Calculation:

A Roman shade is 48" wide and 68" long. Use our Fractional Calculator (Stock #: **DYC6**) to help with the fractional calculation.

Suppose lift cords will be evenly spaced about 12" apart and the most outer lift cords will be 1" away from the side edges of the shade.

$$48'' - 2'' = 46'' \div 12 = 3.8333$$

Round to the nearest whole number, 4.

$$48'' - 2'' = 46'' \div 4 = 11\frac{1}{2}''$$

So, the lift cords will actually be placed 11 1/2" apart.

Suppose approximately 6" fold size is desired and there will be a skirt, the length of which is half of the fold size.

$$68'' \div 6'' = 11.3333$$

Round to the nearest half number, 11.5.

$$68'' \div 11.5 = 5\frac{7}{8}''$$

The ring to ring distance will be 5 7/8".

The actual skirt length can be calculated as follows,

$$5\frac{7}{8}'' \times 11 = 64\frac{5}{8}''$$

$$68'' - 64\frac{5}{8}'' = 3\frac{3}{8}''$$

Marking Ring Positions

Use the sample given above, The figure below shows the desired ring positions.

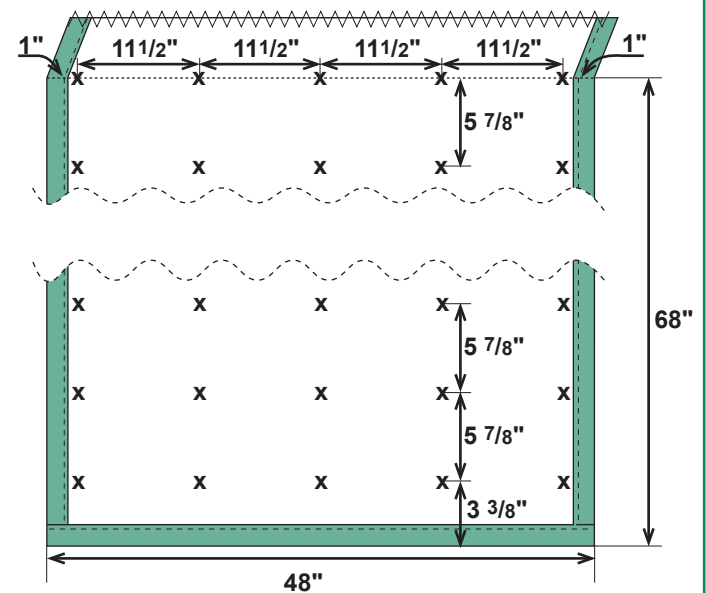

1. Assemble the shade to the size as usual.

With our erasable marking pen (Stock #: **PM21** or **PM22**; **PM21**, the purple pen is used as example in this instruction), draw a purple line for the bottom skirt (**A**) and draw another one for the top finished fold (**B**). Along each purple line, mark a purple dot 1" away from the side edge (**C**).

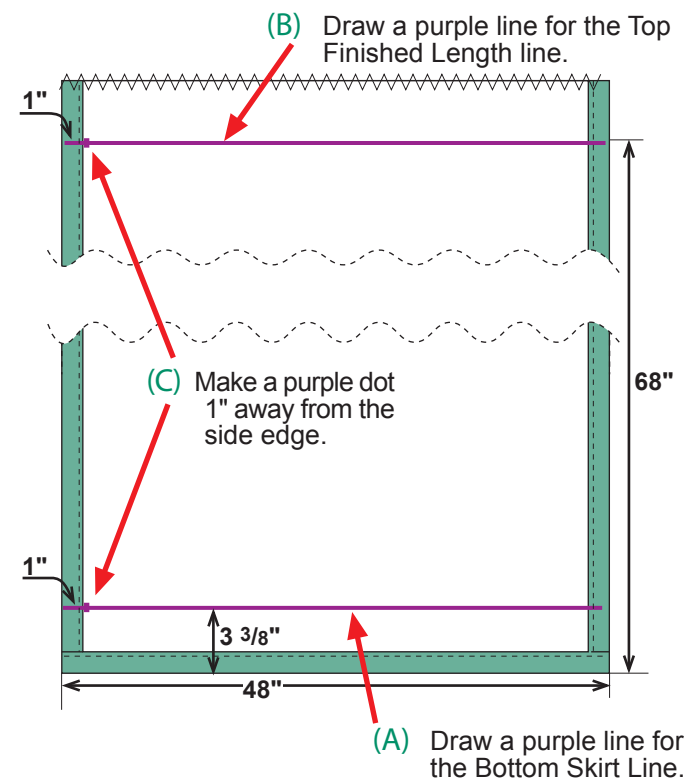

1"

- Turn the template side ways, so the bottom edge of the template is at the left side. Place the orange line marked as $11\frac{1}{2}$ " on the purple line for the Bottom Skirt (A). Align the purple dot on the shade with the $11\frac{1}{2}$ " mark next to the slot (B). With erasable marking pen, mark a purple dot next to the $11\frac{1}{2}$ " mark through each slot (C).

Repeat the same procedure along the Purple line for the Top Finished Length Fold.

When you have finished Step 2, you should have your shade marked like the figure below:

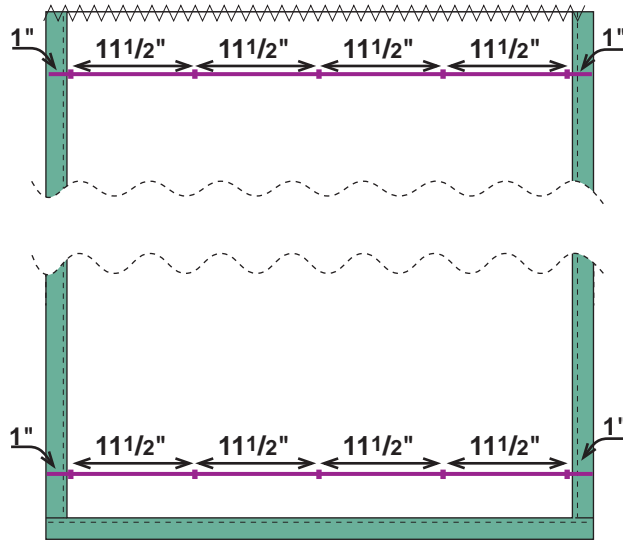

- (A) Place the orange line marked as $11\frac{1}{2}$ " on the purple line.

- (C) With erasable marking pen, mark a purple dot next to the $11\frac{1}{2}$ " mark through each slot. The red arrows below show where to mark.

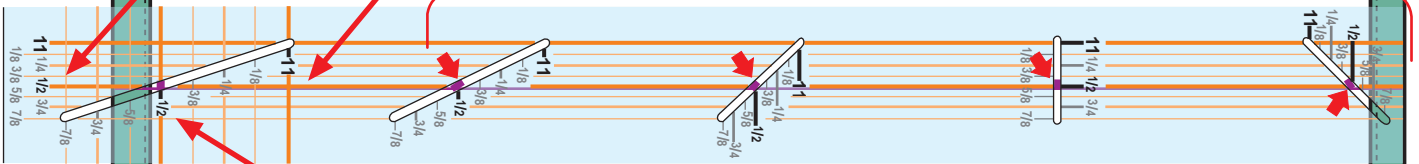

- (B) Align the purple dot on the shade with the $11\frac{1}{2}$ " mark next to the slot.

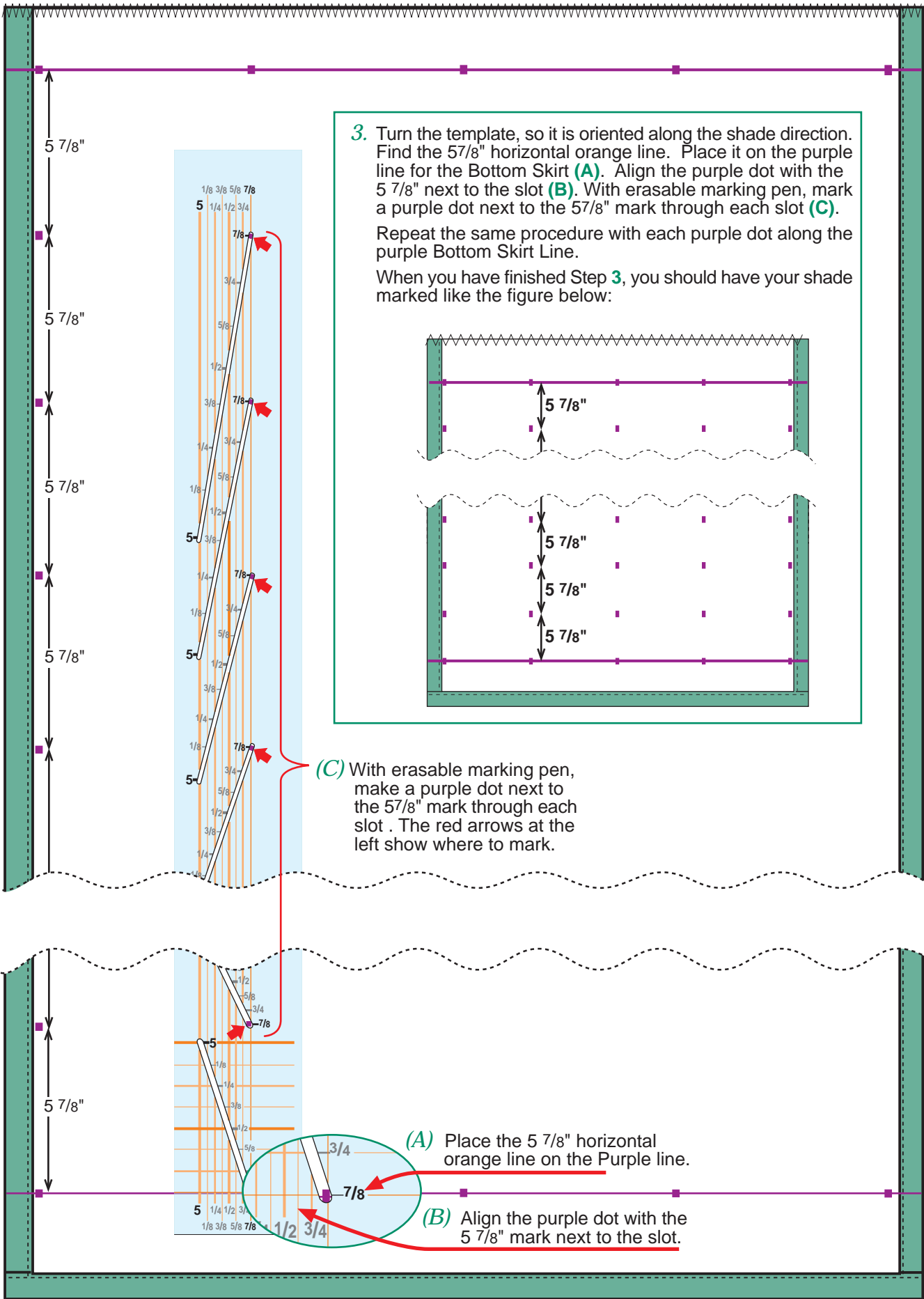

3. Turn the template, so it is oriented along the shade direction. Find the $5\frac{7}{8}$ " horizontal orange line. Place it on the purple line for the Bottom Skirt (A). Align the purple dot with the $5\frac{7}{8}$ " mark next to the slot (B). With erasable marking pen, mark a purple dot next to the $5\frac{7}{8}$ " mark through each slot (C). Repeat the same procedure with each purple dot along the purple Bottom Skirt Line. When you have finished Step 3, you should have your shade marked like the figure below:

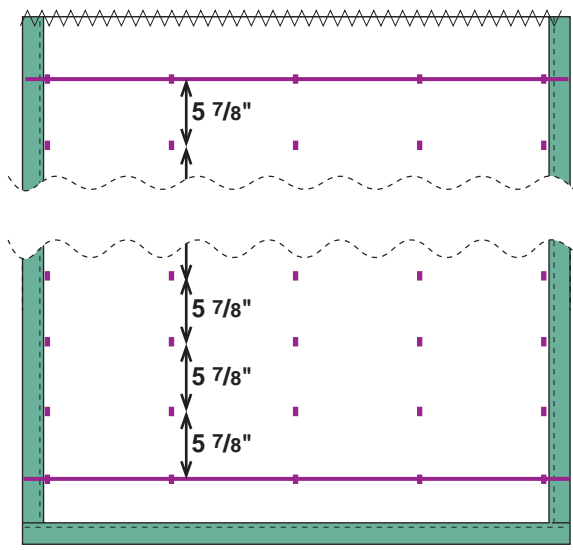

(C) With erasable marking pen, make a purple dot next to the $5\frac{7}{8}$ " mark through each slot. The red arrows at the left show where to mark.

(A) Place the $5\frac{7}{8}$ " horizontal orange line on the Purple line.

(B) Align the purple dot with the $5\frac{7}{8}$ " mark next to the slot.

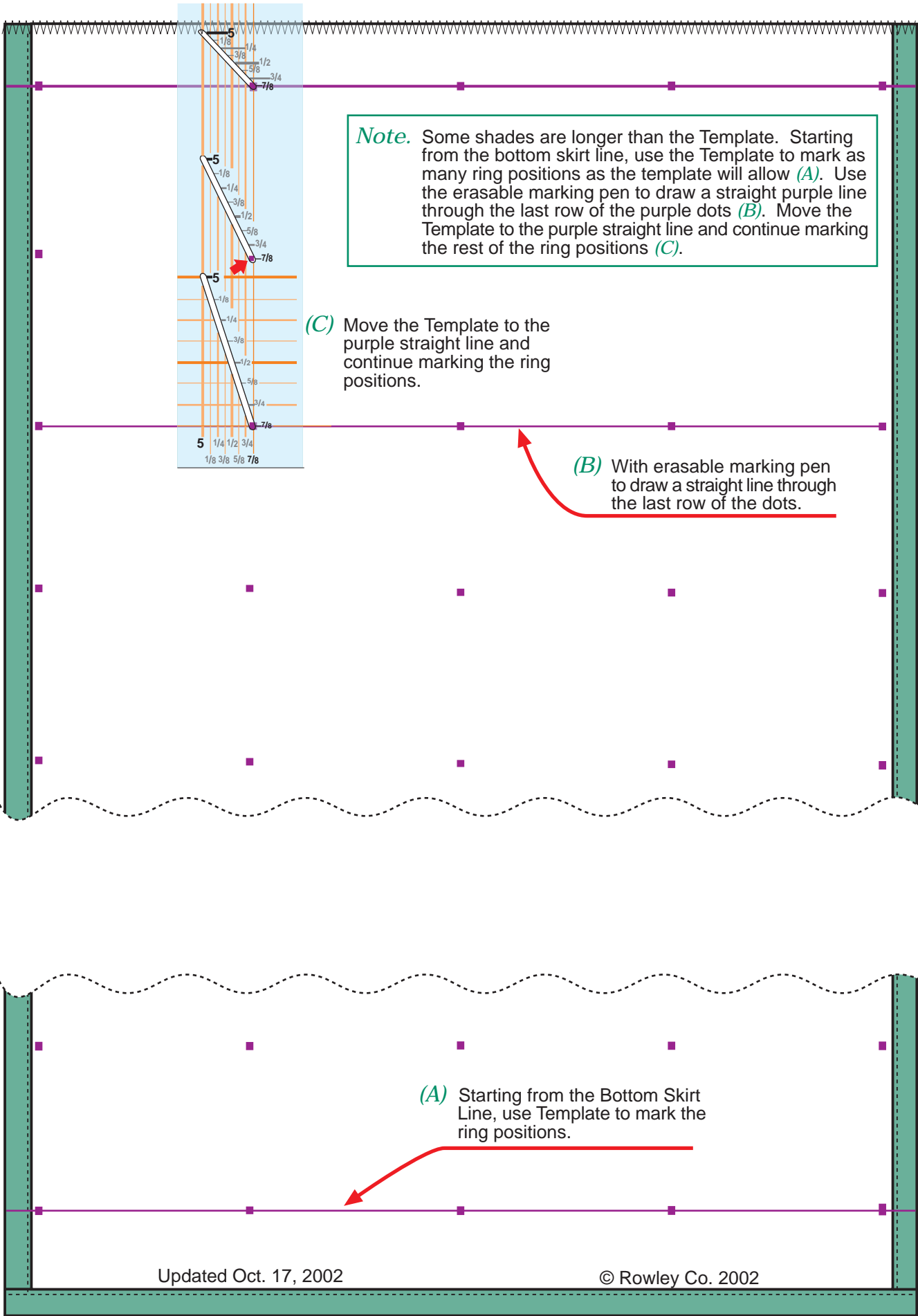

Note. Some shades are longer than the Template. Starting from the bottom skirt line, use the Template to mark as many ring positions as the template will allow (A). Use the erasable marking pen to draw a straight purple line through the last row of the purple dots (B). Move the Template to the purple straight line and continue marking the rest of the ring positions (C).

(C) Move the Template to the purple straight line and continue marking the ring positions.

(B) With erasable marking pen to draw a straight line through the last row of the dots.

(A) Starting from the Bottom Skirt Line, use Template to mark the ring positions.